



SATA M.2 ArmourDrive™

87 Series

Product Brief

Product Description

The SATA M.2 ArmourDrive™ family consists of high-reliability, industrial solid state drives (SSDs) in a wide selection of capacities and endurance specifications. To better address customer needs, the 87 Series is available with 1-bit-per-cell (SLC) or 3-bit-per-cell (TLC) 3D NAND configurations. ArmourDrive SSDs designed with Greenliant's EnduroSLC™ Technology can reach ultra-high write endurance of 400K program/erase (P/E) cycles. Operating at extreme temperatures, SATA M.2 ArmourDrive is ideal for applications requiring removable data storage able to withstand the most demanding environments.

The 87 Series implements advanced NAND flash management technology to preserve data integrity and extend SSD lifespan. Built in the standard 2242 and 2280 form factors and backed by Greenliant's technical support, SATA M.2 ArmourDrive gives industrial, computing, security, video and networking customers added flexibility when selecting reliable solid state storage for space-constrained, embedded systems.



Key Features

Industrial SATA M.2 SSDs

- 2242 (22mm x 42mm) and 2280 (22mm x 80mm), B+M key
- Supports SATA 6Gb/s, 3Gb/s and 1.5Gb/s
- Compliant with SATA Revision 3.2

High Performance

- Sequential Read / Write performance up to 550MB/s / 510MB/s
- Native Command Queuing up to 32 commands
- DRAM for better sustained performance (select PX Series SSDs)

Energy Efficient

- 3.3V low power supply
- Standby Mode less than 210mW
- Sleep Mode less than 40mW
- DevSleep Mode support

Pre-programmed Firmware

- Field-upgradeable firmware to add new features and enhance device performance
- Configurable algorithms optimize data retention based on the usage model
- Embedded FFS enables seamless capacity upgrade with no change to host software

Advanced Flash Management

- Dynamic and static wear leveling algorithms maximize product lifespan
- Supports TRIM commands to remove invalid data which is no longer in use
- Replaces bad blocks with spare blocks in the NAND flash to prevent uncorrectable errors

High Reliability

- MTBF more than 2,000,000 hours

Built-in ECC

- Uses advanced bit error detection and correction optimized for 3D NAND

SSD Lifespan Monitoring

- Supports SMART command-based alerts indicating the remaining useful product life

Power Interrupt Data Protection

- Helps prevent data loss during power failures

Data Security

- Secure Erase for quick data wipe/factory reset
- AES-256 / TCG OPAL hardware encryption (select PX Series SSDs)

Wide Range of Capacities

- SLC (EX Series): 10 GB - 320 GB
- TLC (PX Series): 64 GB - 2 TB



Applications

- Industrial automation & control
- Base station equipment
- Digital signage
- Industrial PC
- Thin client
- Transportation system
- Test & measurement instrumentation
- Network server
- Gateway / Switch
- Banking terminal / ATM
- Security equipment
- Surveillance
- Data recorder
- Video conferencing
- Medical equipment
- Multi-function printer

Greenliant

3970 Freedom Circle, Suite 100

Santa Clara, CA 95054 USA

Tel: 1-408-200-8000

Fax: 1-408-200-8099

www.Greenliant.com

SATA M.2 ArmourDrive Board Diagrams

Double Sided (DS): 22mm x 42mm x 3.18 / 3.58 / 3.80mm / 22mm x 80mm x 3.18 / 3.58 / 3.80mm

Single Sided (SS): 22mm x 42mm x 2.38mm / 22mm x 80mm x 2.38mm

Pb-free (RoHS compliant)

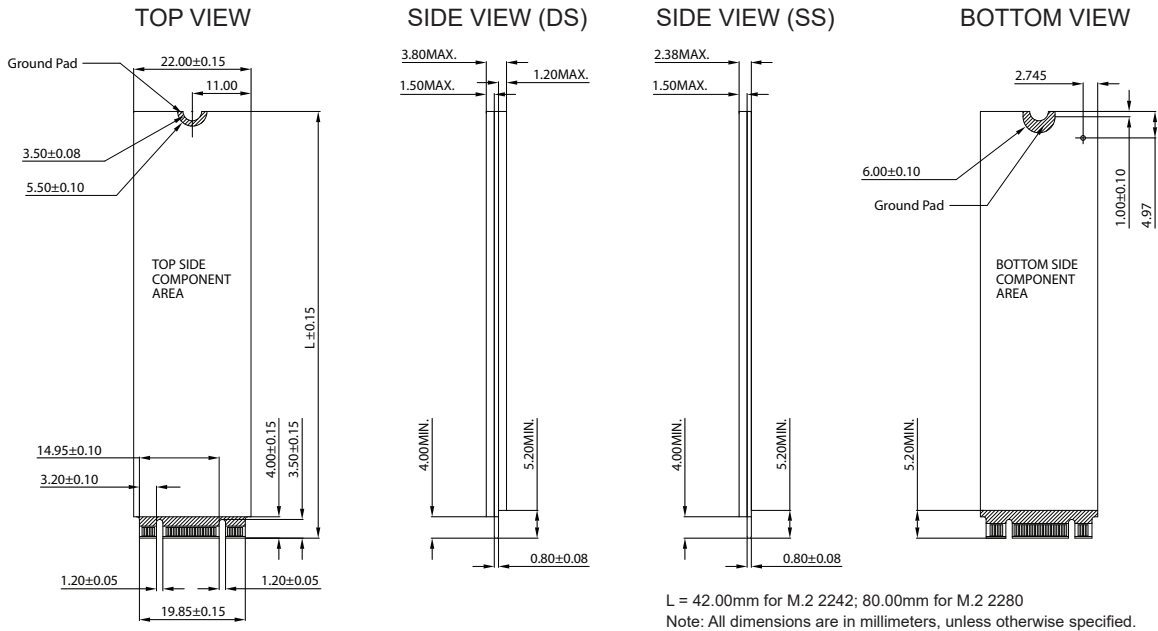

SATA M.2 ArmourDrive Block Diagram

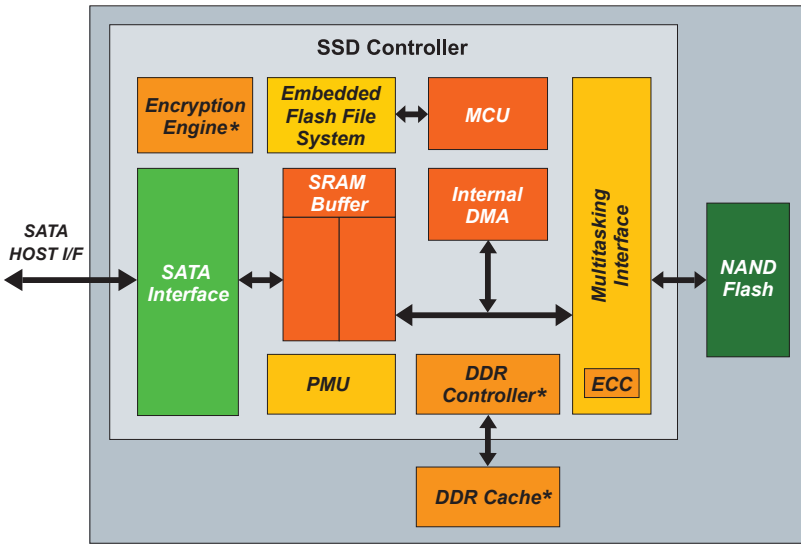



*Available on select PX Series products

Product Lineup

87 Series SATA M.2 ArmourDrive			
Product Series / Capacity	Form Factor	NAND Configuration / Endurance	Temperature Range
EX 10 GB - 320 GB	2242 SS	1-bit-per-cell SLC NAND / 75K, 150K, 400K P/E cycles*	Industrial -40°C to +85°C
PX 240 GB - 1.92 TB (with DRAM)	2280 DS	3-bit-per-cell TLC NAND / 3K P/E cycles	
PX PX 64 GB - 1 TB	2242 DS		Industrial -40°C to +85°C
PX PX 64 GB - 2 TB	2280 DS		Commercial 0°C to +70°C

*Designed with Greenliant's advanced EnduroSLC Technology 400K endurance offered up to 160GB - Built to Order (BTO) / additional terms apply

EnduroSLC™

 twitter.com/Greenliant
 linkedin.com/company/Greenliant
 facebook.com/Greenliant

ArmourDrive FAQs: www.greenliant.com/armourdrive-faqs

For more information, contact your Greenliant representative: www.greenliant.com/sales



© 2024 Greenliant
Greenliant, the Greenliant logo, EnduroSLC and ArmourDrive are trademarks of Greenliant.
These specifications are subject to change without notice. 04/2024