

Features

- **Industry Standard PCIe Host Interface**
 - PCIe Gen4x4
 - PCI Express Base Revision 3.1 compliant
 - NVMe 1.4 compliant
- **Performance**
 - Sequential data read: Up to 3,600 MB/s
 - Sequential data write: Up to 2,400 MB/s (measured using 128KB transfer size)
- **Power Management**
 - 3.3V single power supply
 - Autonomous power state transition (APST) feature to implement power savings
 - Active state power management (ASPM) to reduce PCIe link power consumption
 - Supports L1.2
- **Power Consumption**
 - Active mode:
 - 1TB: < 4,700 mW
 - 512GB: < 4,800 mW
 - 256GB: < 4,500 mW
 - Idle mode: < 40 mW
 - L1.2 mode: < 5 mW
- **Supports SMART and TRIM Commands**
- **32-bit Addressing Mode**
- **512 Byte / 4 KB Sector Size Support**
- **Reliability**
 - Mean Time Between Failures (MTBF): 1.5 million hours
- **Data Protection**
 - End-to-end data path protection
 - Secure erase / Data sanitization
 - Supports TCG Pyrite
- **Host Memory Buffer (HMB)**
- **IO Queuing**
 - 128 IO queues supported
- **Built-in ECC**
 - Uses advanced LDPC bit error detection and correction optimized for 3D NAND
- **NAND Configuration**
 - 3 bits per cell (3D TLC NAND)
- **Endurance**
 - Program/ Erase (P/E) cycles: 3K
 - TeraBytes Written (TBW): Up to 600
- **Operating Temperature Range**
 - Commercial: 0°C to 70°C
- **M.2 2230 Form Factor**
 - 22mm x 30mm x 2.23mm (max)
 - Single-sided (SS), M key
- **All Devices are RoHS Compliant**

Notes: 1. User capacity: 1GB = 1 billion bytes, 1TB = 1 trillion bytes
2. PCIe = Peripheral Component Interconnect Express
3. NVMe = Non-Volatile Memory Express

Product Description

The GLS88ET256G3 / 512G3 / 001T3 Commercial Temperature NVMe M.2 2230 ArmourDrive™ PX Series (referred to as “M.2 ArmourDrive” in this factsheet) are high-performance, high-reliability solid state drives. They combine 256 or 512 GBytes, or 1 TByte of NAND flash memory with an advanced NVMe PCIe controller on a printed circuit board (PCB). NVMe is a highly scalable protocol optimized for efficient data transport over PCIe for storage on NAND flash.

M.2 ArmourDrive is ideal for applications that require removable form factor and more reliable data storage. NVMe M.2 solid state storage technology is used in industrial and cloud computing, datacenters, high-performance enterprise storage and networking systems, endpoint and thin clients, gaming machines and broadcasting equipment. These removable solid state drives (SSDs) provide low latency and fast sequential and random read/write speeds.

The NVMe PCIe SSD controller with built-in advanced NAND management firmware communicates with the host through the standard PCIe interface. It does not require any additional or proprietary software such as the Flash File System (FFS) and Memory Technology Driver (MTD). The firmware effectively optimizes the use of NAND flash memory’s program/erase (P/E) cycles and minimizes write amplification.

M.2 ArmourDrive’s advanced NAND management technology improves endurance, enhances data security and helps prevent data corruption during unexpected power failure events. This innovative technology combines robust NAND controller hardware error correction capabilities with advanced wear-leveling algorithms and bad block management to improve data reliability and significantly extend the life of the product.

1.0 GENERAL DESCRIPTION

Each M.2 ArmourDrive module integrates an NVMe PCIe SSD controller with up to four NAND flash multi-chip packages. Refer to Figure 2-1 for the M.2 ArmourDrive block diagram.

1.1 Optimized M.2 ArmourDrive

The heart of M.2 ArmourDrive is the NVMe PCIe SSD controller, which translates standard PCIe signals into flash media data and control signals. The following components contribute to M.2 ArmourDrive's operation.

1.1.1 Microcontroller Unit (MCU)

The MCU translates PCIe / NVMe commands into data and control signals required for flash media operation.

1.1.2 Internal Direct Memory Access (DMA)

M.2 ArmourDrive uses internal DMA allowing instant data transfer from/to buffer to/from flash media. This implementation eliminates microcontroller overhead associated with the traditional, firmware-based approach, thereby increasing the data transfer rate.

1.1.3 Power Management Unit (PMU)

The PMU controls the power consumption of M.2 ArmourDrive. The PMU dramatically reduces the power consumption of M.2 ArmourDrive by putting the part of the circuitry that is not in operation into sleep mode.

The Flash File System handles inadvertent power interrupts and has auto-recovery capability to ensure M.2 ArmourDrive firmware integrity.

1.1.4 Embedded Flash File System

The embedded flash file system is an integral part of M.2 ArmourDrive. It contains MCU firmware that performs the following tasks:

1. Translates host side signals into flash media writes and reads
2. Provides flash media wear leveling to spread the flash writes across all memory address space to increase the longevity of flash media
3. Keeps track of data file structures

1.1.5 Power Interrupt Data Protection

Power Interrupt Data Protection is a mechanism to prevent data corruption during unexpected power failure events. Enhanced data integrity is supported by the controller's advanced firmware during abnormal power loss. The controller proactively optimizes the amount and stay time of the "in-flight" data residing in the cache. To ensure there is no data loss risk caused by power cycling, the controller sends an acknowledgement to the host only when the incoming data is fully committed to the NAND flash.

1.1.6 Error Checking and Correction (ECC)

The ECC technology uses advanced LDPC algorithms to detect and correct errors, ensuring data integrity and extending the SSD lifespan.

1.1.7 Multi-tasking Interface

The multi-tasking interface enables concurrent Read, Program and Erase operations to multiple NAND flash media.

1.2 Advanced NAND Management

M.2 ArmourDrive's controller uses advanced wear-leveling algorithms to substantially increase the longevity of NAND flash media. Wear caused by data writes is evenly distributed in all or select blocks in the device that prevents "hot spots" in locations that are programmed and erased extensively. This effective wear-leveling technique results in optimized device endurance, enhanced data retention and higher reliability required by long-life applications.

1.3 Advanced Data Security

Advanced data security measures include end-to-end data path protection, data sanitization and Secure Erase support. Secure Erase is an effective method to quickly wipe all data from a PCIe-based SSD using the NVMe protocol (Format NVM).

2.0 FUNCTIONAL BLOCKS

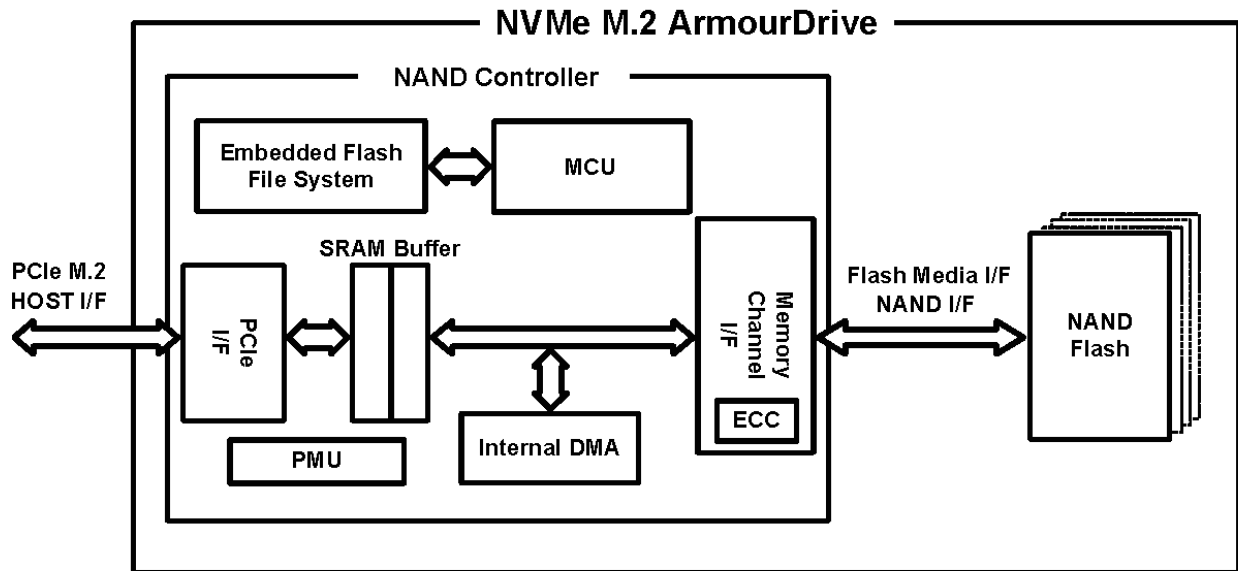
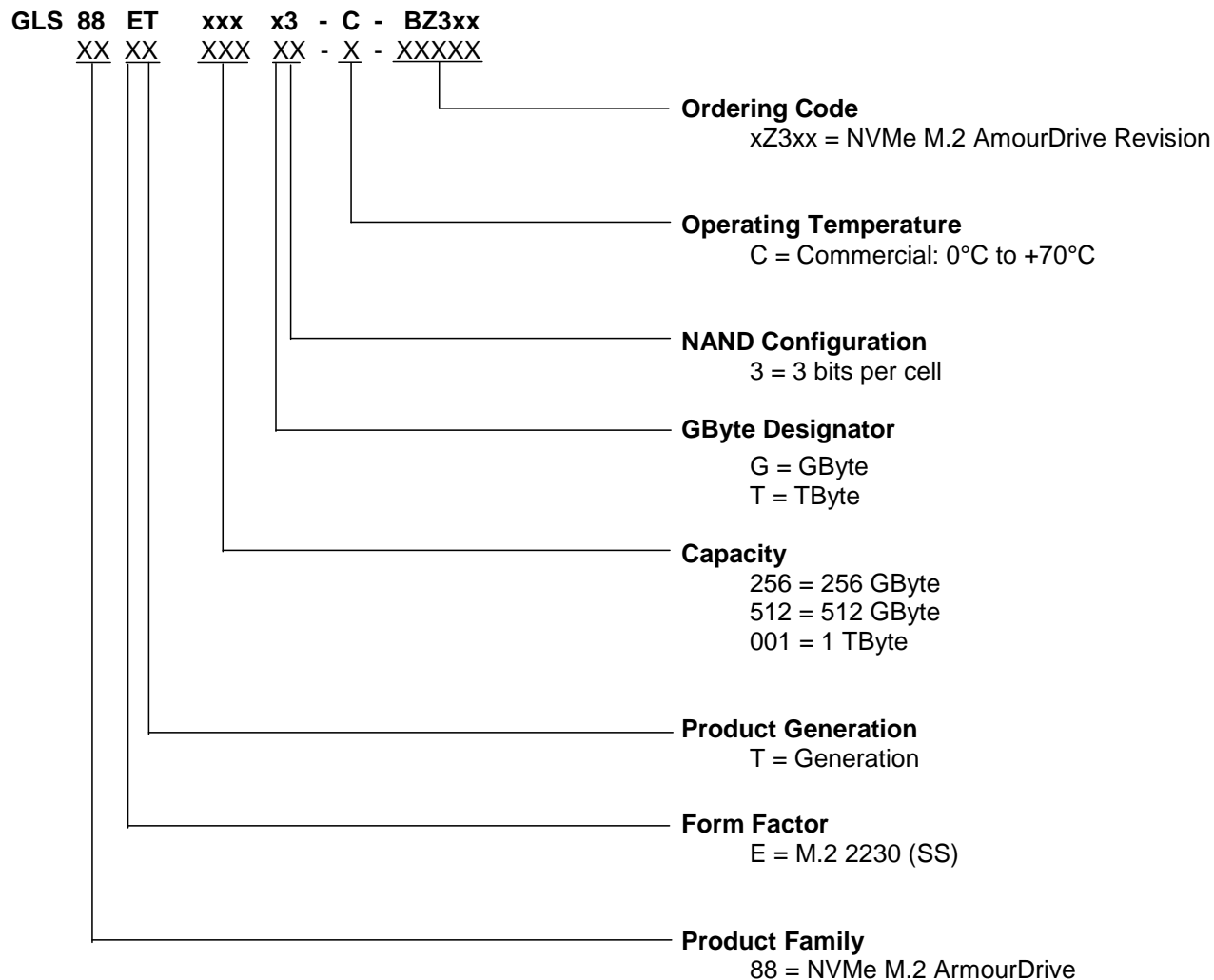

Figure 2-1: M.2 ArmourDrive Block Diagram

3.0 APPENDIX

3.1 Product Ordering Information



Valid Combinations

Valid product combinations are those that are in the mass production or will be in the mass production. Consult your Greenliant sales representative to confirm availability of the valid combinations and to determine availability of new product combinations.

Table 3-1: M.2 ArmourDrive Product Valid Ordering Numbers

Capacity	Operating Temperature	Part Number	Form Factor
256GB	Commercial (0°C to 70°C)	GLS88ET256G3-C-BZ306	2230 (SS), M key
512GB	Commercial (0°C to 70°C)	GLS88ET512G3-C-BZ306	2230 (SS), M key
1TB	Commercial (0°C to 70°C)	GLS88ET001T3-C-BZ306	2230 (SS), M key

3.2 Board Diagrams

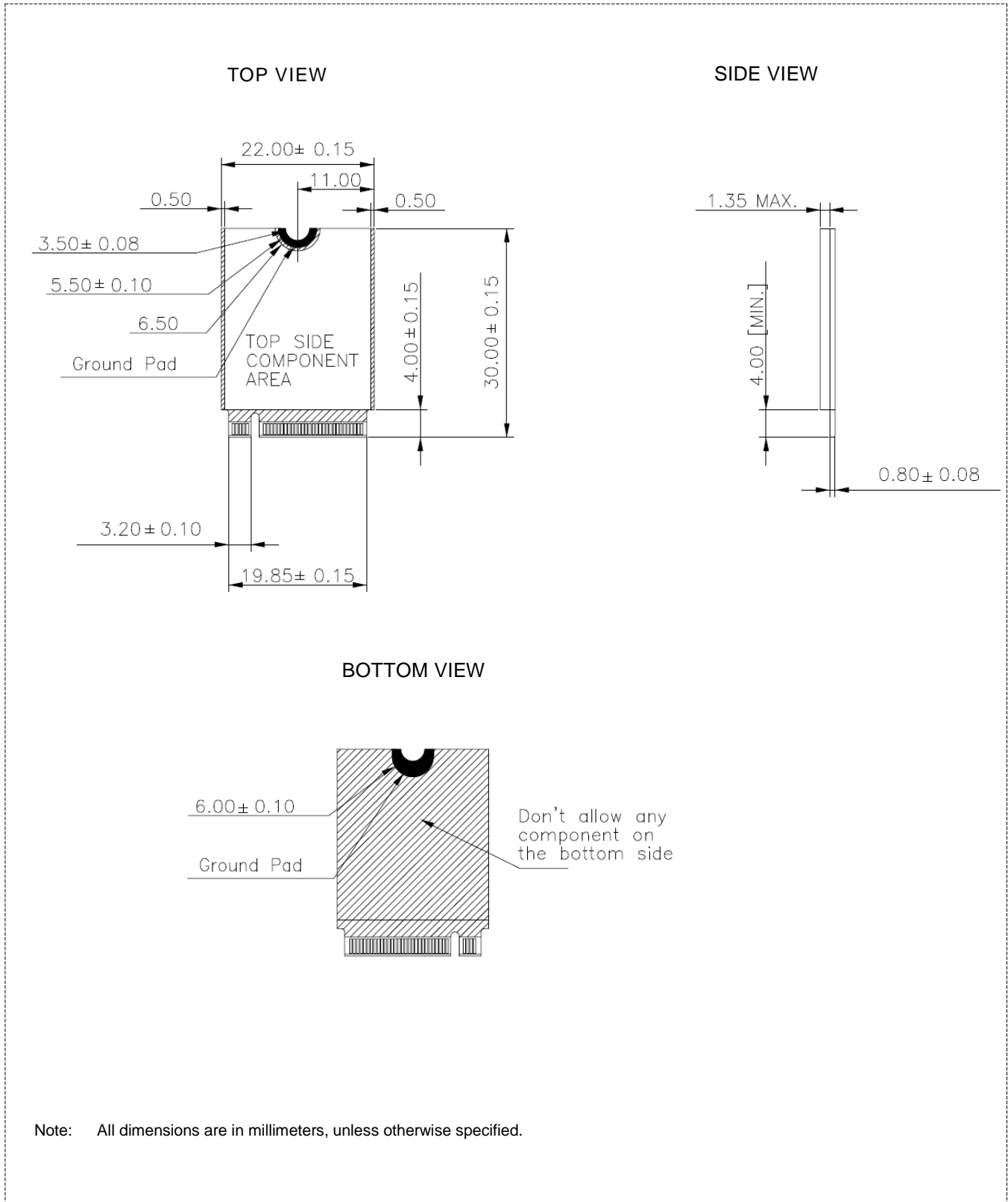

Figure 3-1: M.2 2230 ArmourDrive Dimensions

Revision History

Number	Description	Date
01.000	Initial release as Factsheet	December 22, 2022

© 2022 Greenliant. All rights reserved.

Greenliant and the Greenliant logo are registered trademarks, and ArmourDrive is a trademark of Greenliant. All other trademarks and registered trademarks are the property of their respective owners.

Specifications are subject to change without notice. Memory sizes denote raw storage capacity; actual usable capacity may be less.

Greenliant makes no warranty for the use of its products other than those expressly contained in the Greenliant Terms and Conditions of Sale.

www.greenliant.com